

Adapter Flange DN 40 – DN 125

The **asa** suction unit is screwed to the **asa** adapter flange, which is welded to the tank. Due to low installation costs and compact design, purchasing **asa** suction units is cost effective. A switch (mechanical or inductive) can be mounted on the standard block for monitoring matters. The adapter flange may only be welded with demounted butterfly flange.

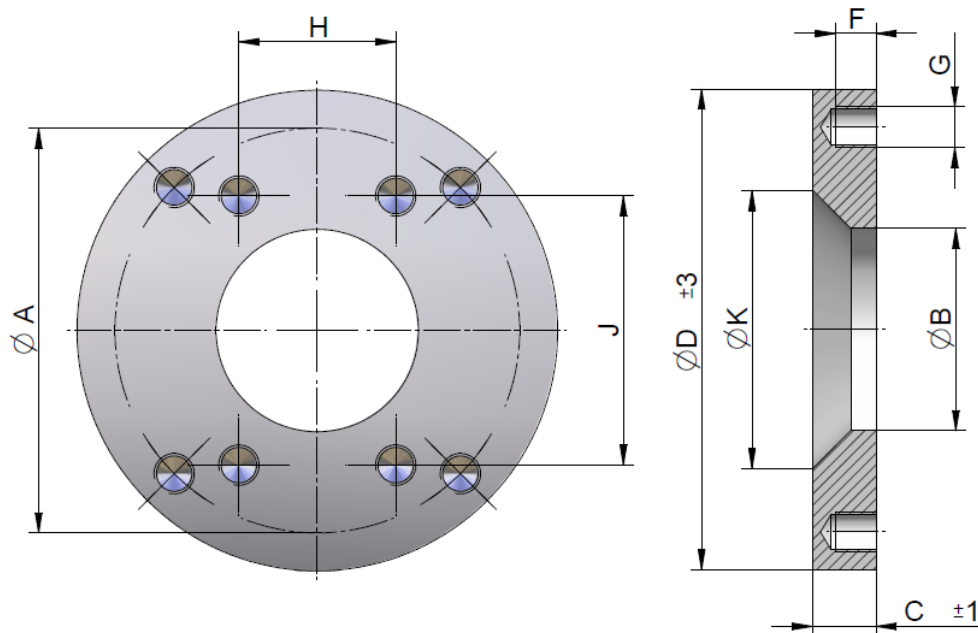

Technical Data

order number	description	A	B	C	D	F	G	H	J	K	weight
		[mm]	[mm]	[mm]	[mm]	[mm]	[mm]	[mm]	[mm]	[mm]	[kg]
SDAET040K	adapter 40	110	49	25	130	14	M12 (4x)	--	--	89 ± 1	1,85
SDAET063K	adapter 50 & 63	125	63	25	150	16	M12 (4x)	--	--	103 ± 1	2,45
SDAET080K	adapter 80	--	82	25	150	14	M16 (4x)	62	106,4	109 ± 1	2,14
SDAET100K	adapter 100	--	103	25	180	14	M16 (4x)	77,8	130	139 ± 1	2,80
SDAET125K	adapter 125	--	128	25	205	14	M16 (4x)	92	152,4	164 ± 1	3,30

Material

flange material	steel 1.0037 or 1.0570
-----------------	------------------------

Material

delivery condition	oiled
--------------------	-------

Fits On

SDAET040K	SDA0040, SDA00040
SDAET063K	SDA0050, SDA0063, SDA00050, SDA00063
SDAET080K	SDA0080, SDA00080
SDAET100K	SDA0100, SDA00100
SDAET125K	SDA0125, SDA00125

