

# Adapter Flange

## DN 40 – DN 125

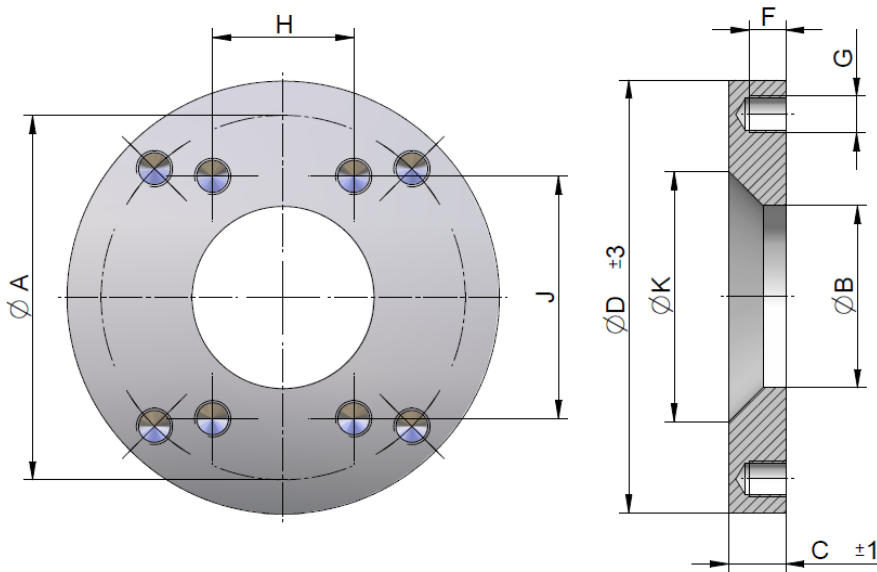

The *asa* suction unit (butterfly flange) is screwed to the *asa* adapter flange, which is welded to the tank. Due to low installation costs and compact design, purchasing *asa* suction units is cost effective. The adapter flange may only be welded with demounted butterfly flange.



### Technical Data

order number	description	A	B	C	D	F	G	H	J	K	weight
		[mm]	[mm]	[mm]	[mm]	[mm]	[mm]	[mm]	[mm]	[mm]	[kg]
SDAET040K	adapter 40	110	49	25	130	14	M12 (4x)	--	--	89 ± 1	1,85
SDAET063K	adapter 50 & 63	125	63	25	150	16	M12 (4x)	--	--	103 ± 1	2,45
SDAET080K	adapter 80	--	82	25	150	14	M16 (4x)	62	106,4	109 ± 1	2,14
SDAET100K	adapter 100	--	103	25	180	14	M16 (4x)	77,8	130	139 ± 1	2,80
SDAET125K	adapter 125	--	128	25	205	14	M16 (4x)	92	152,4	164 ± 1	3,30

### Material

flange material	steel
-----------------	-------

### Delivery Condition

delivery condition	oiled
--------------------	-------

### Fits On

SDAET040K	SDA0040
SDAET063K	SDA0050 & SDA0063
SDAET080K	SDA0080
SDAET100K	SDA0100
SDAET125K	SDA0125



This data sheet and the corresponding scale drawings are to be used as a general guideline and technical overview of our products. Please contact us if more exact information is needed. As we are constantly improving our products, their characteristics, dimensions and weights may also change, although we do our best to incorporate these changes continually. *asa* assumes no liability for any information therein, any errors, omissions, misprints, nor any direct or indirect damages, losses or costs resulting therefrom. Any cooling performances and general technical values indicated in this catalogue are measured at a test bench according to *asa* testing procedures or calculated, based on such tests. They represent a basis for your product selection. Due to different conditions in testing and application environments the performance may also vary by +/- 15%. All sound values are determined in accordance with ISO 9614-2, DIN EN ISO 11203 accuracy class 3 or Machinery Directive 2006/42/EG and are A-rated. At some of the performance data, possible differences to competition data are possible. The reason for that are no existing standardized testing procedures on individual subjects, e.g. for cooling performance measurements. Therefore, we recommend all products to be checked under the system operating conditions. This is also true of vibrations and mechanical stress as well as for pressure peaks and thermal stress and any other relevant factors. General tolerances according to DIN ISO 2768-vL. General tolerances for casted parts according to EN ISO 8062-3 (DCTG 10). Tolerances for rubber parts are according to ISO 3302-1 (class M4-F+C). The tolerances of welding seams are defined by quality group D according to EN ISO 10042, if it is not specified on the actual scale drawing or data sheet. Any form of liability is excluded for the information included in this datasheet. All details and calculation values are checked to the best of our ability, but these do not ensure any intrinsic product properties: due to the wide-ranging possible applications, it is advised that all technical data herewith included be confirmed through testing carried out by the end-user. *asa technology Produktions- und Vertriebs GmbH* reserves the right to modify the product without any separate notification. This refers to both technical data and the product itself. Furthermore, it is herewith specified that the datasheet does not substitute the corresponding scale drawings, assembly and installation guidelines, nor the operating instructions.

DD-SDAET-en-rev5 © *asa technology*, August 2025 1/1